

# Illinois Microreactor Demonstration Project

Joint 2023 TRTR/IGORR Research Reactor Conference | June 19, 2023



UNIVERSITY OF  
**ILLINOIS**  
URBANA-CHAMPAIGN

- University of Illinois Urbana-Champaign Project Team
- Nuclear Projects: Big Picture
- Need: Next Generation Workforce
- About the University of Illinois Urbana-Champaign
- Project Focus
- Reactor Design: Ultra Safe Nuclear Corporation Micro-Modular Reactor (MMR™)
- MMR Fuel
- Licensing Documentation and Current Schedule

# UIUC Project Team



Dr. C.S. Brooks      Dr. A. Di Fulvio      Dr. T. Kozlowski      Dr. J.F. Stubbins      Dr. R. Uddin



Mr. L. Foyto      Dr. T. Grunloh      Dr. W.R. Roy      Mr. C. Townsend

Harun Ardiansyah  
Joe Bottini  
Anthony Boyd  
Roberto Fairhurst  
Aya Hegazy  
Kholod Mahmoud  
Brady Moore  
Ethan Nicolls  
Natalie Panczyk  
Bella Paquette  
Mouna Soumahoro

Reactor Site

Reactor Technology

License

Fuel

Insurance

Public Engagement

## ➤ Why University of Illinois Campus?

- Long legacy in pioneering Nuclear Engineering
- Large energy user (steam, electricity, chilled water)
- Illinois is the epicenter of US nuclear power industry
- Diverse expertise across all relevant areas of science and engineering
- Ambitious carbon reduction goals
- Infrastructure to meet workforce needs for a clean energy future

Reactor Site

Reactor Technology

License

Fuel

Insurance

Public Engagement

## ➤ Why Ultra Safe Nuclear Corporation?

- Most mature microreactor design
- Builds from known/demonstrated nuclear technology
- Advances state of the art nuclear fuel
- Flexible thermal energy utilization
- World-class team

Reactor Site

Reactor Technology

License

Fuel

Insurance

Public Engagement

## ➤ Why an NRC 104c license?

- Prototype-friendly approach
- Fastest path to demonstration under NRC
- Perform research, development, and demonstration to optimize future commercial deployments
- NRC licensing fee exemption

Reactor Site

Reactor Technology

License

Fuel

Insurance

Public Engagement

## ➤ **Where to get the fuel?**

- US DOE University Fuel Services Program
- Material, fabrication, and transportation
- Lease and take-back program
- Requires federal appropriations

Reactor Site

Reactor Technology

License

Fuel

Insurance

Public Engagement

- **How will microreactors be insured?**
  - Scalability of traditional nuclear insurance framework?
  - State institutions have unique insurance model compared with commercial nuclear operators



Reactor Site

Reactor Technology

License

Fuel

Insurance

Public Engagement

→ **How to redeem public perception of nuclear power?**

- Campus community engagement
- Modern approaches to physical security
- Deployment in populated areas
- RD&D for faster construction, safer operation, reduced costs
- *All roads go through public perception*

# Need: Next Generation Nuclear Workforce

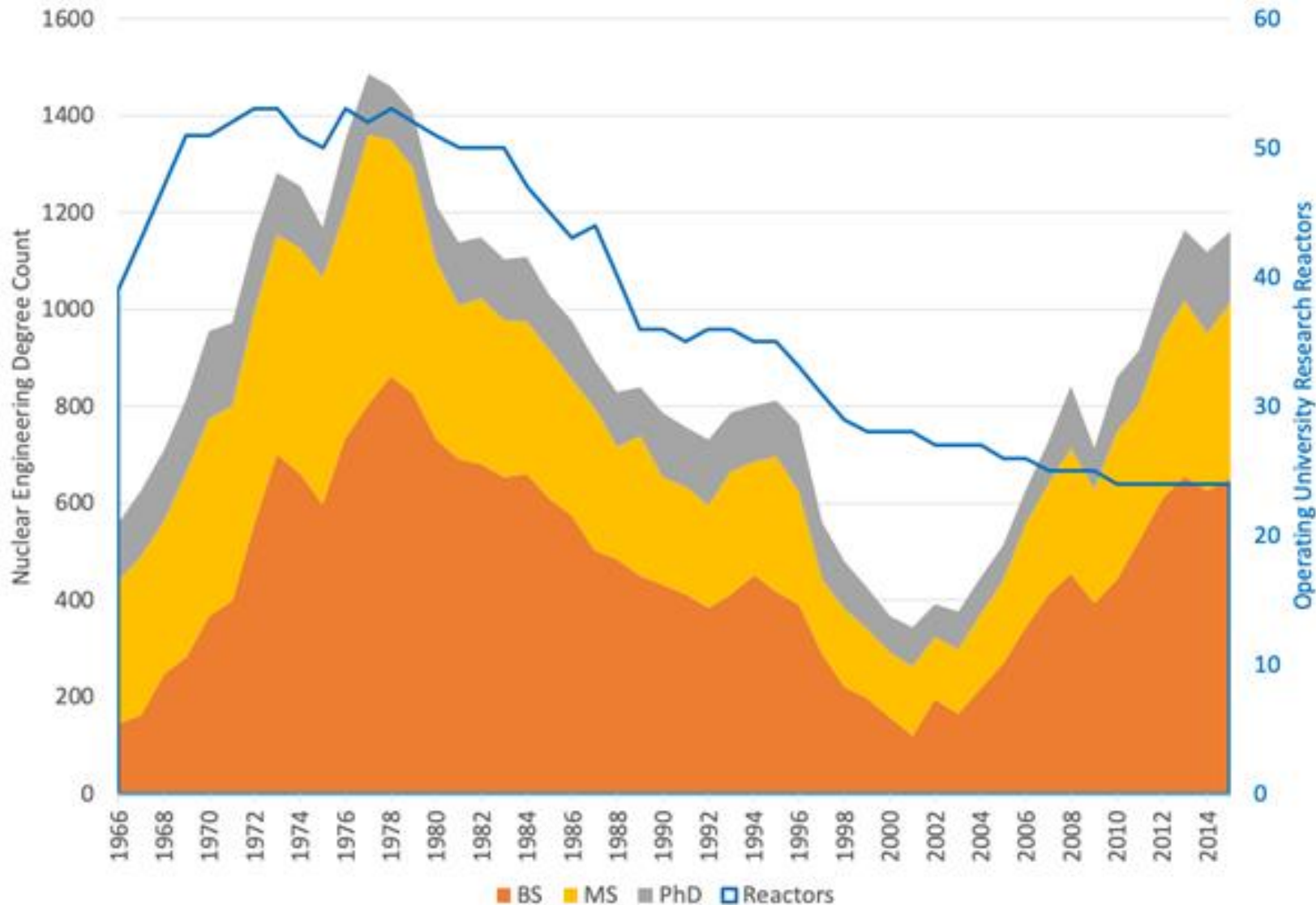

- Resurgence in student interest in nuclear has not been met with new university research reactors for education, training, and research.
- No new university-based research reactors for nearly 30 years.
- Advanced nuclear needs advanced research and test reactors.

Data compiled from ORISE, 2019;  
Morrell et al., 2017; Anderson et al.  
2016

# About the University of Illinois Urbana-Champaign



## University of Illinois Urbana-Champaign

- Public, land-grant university founded in 1867
- Flagship of the University of Illinois system
- \$731M in R&D expenditures in FY2021
- 15 colleges and instructional units
- 651 buildings within 9.9 square miles (6,370 acres)
- 3,029 Faculty
- 56,257 Students
- 470,000+ alumni

## Grainger College of Engineering

- 39 top ten ranked degree programs
- #10 overall graduate program ranking
- #6 nuclear engineering graduate program



‘The University of Illinois at Urbana-Champaign is charged by our state to enhance the lives of citizens in Illinois, across the nation and around the world through our leadership in learning, discovery, engagement and economic development.’

## Core Mission: Education, Training, and Outreach

- general public,
- undergraduate,
- graduate,
- professional, and
- operator training.

## Core Mission: Research Capability

- leverage strength areas across campus,
- reactor testing, research, and development, and
- critical enabling and synergistic technologies.

## Cross-cutting Mission: Production Demonstration

- electricity,
- district heat,
- hydrogen production,
- integrated thermal storage, and
- other high value processes.

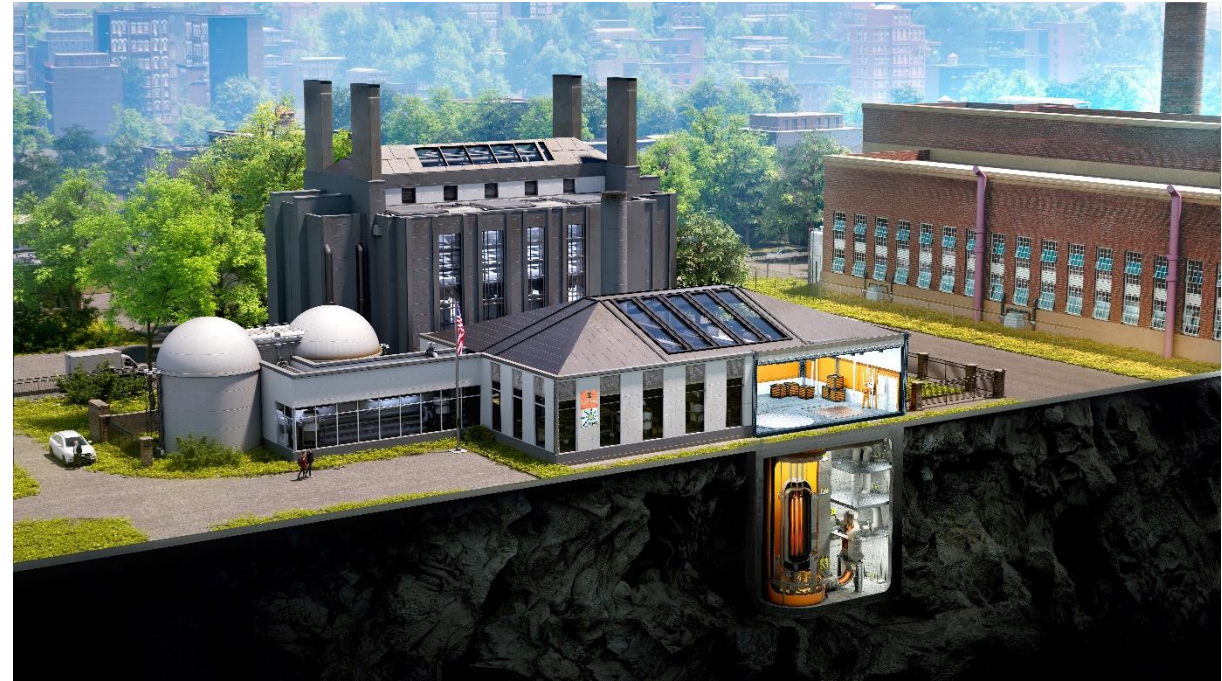

*Consistent with the Atomic Energy Act, Class 104(c) small reactors for **research, testing, and training** can contribute to the **public good** through their role **in higher education, workforce development, research, and technology/market demonstration.***

# Reactor Design: USNC Micro-Modular Reactor (MMR™)

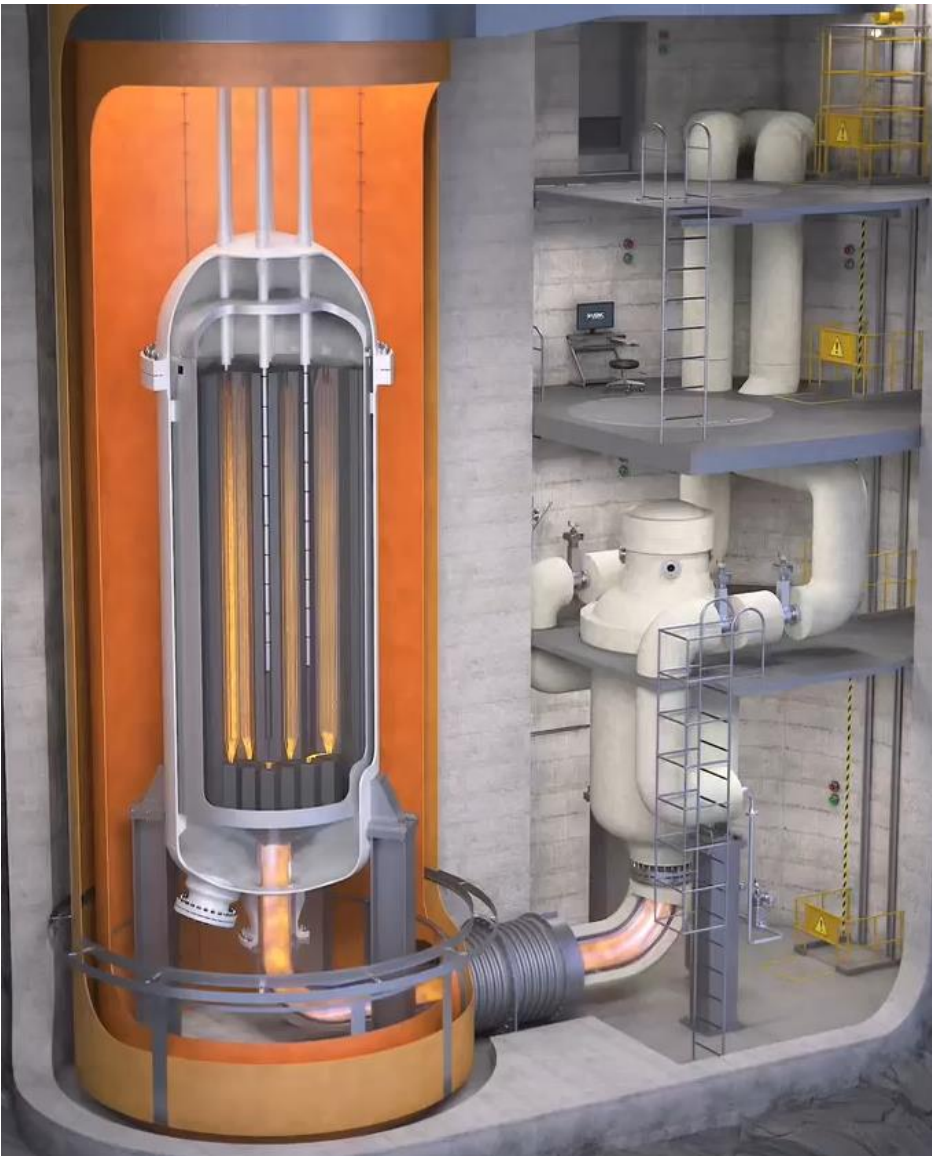

Credit: [USNC](https://www.usnc.com)

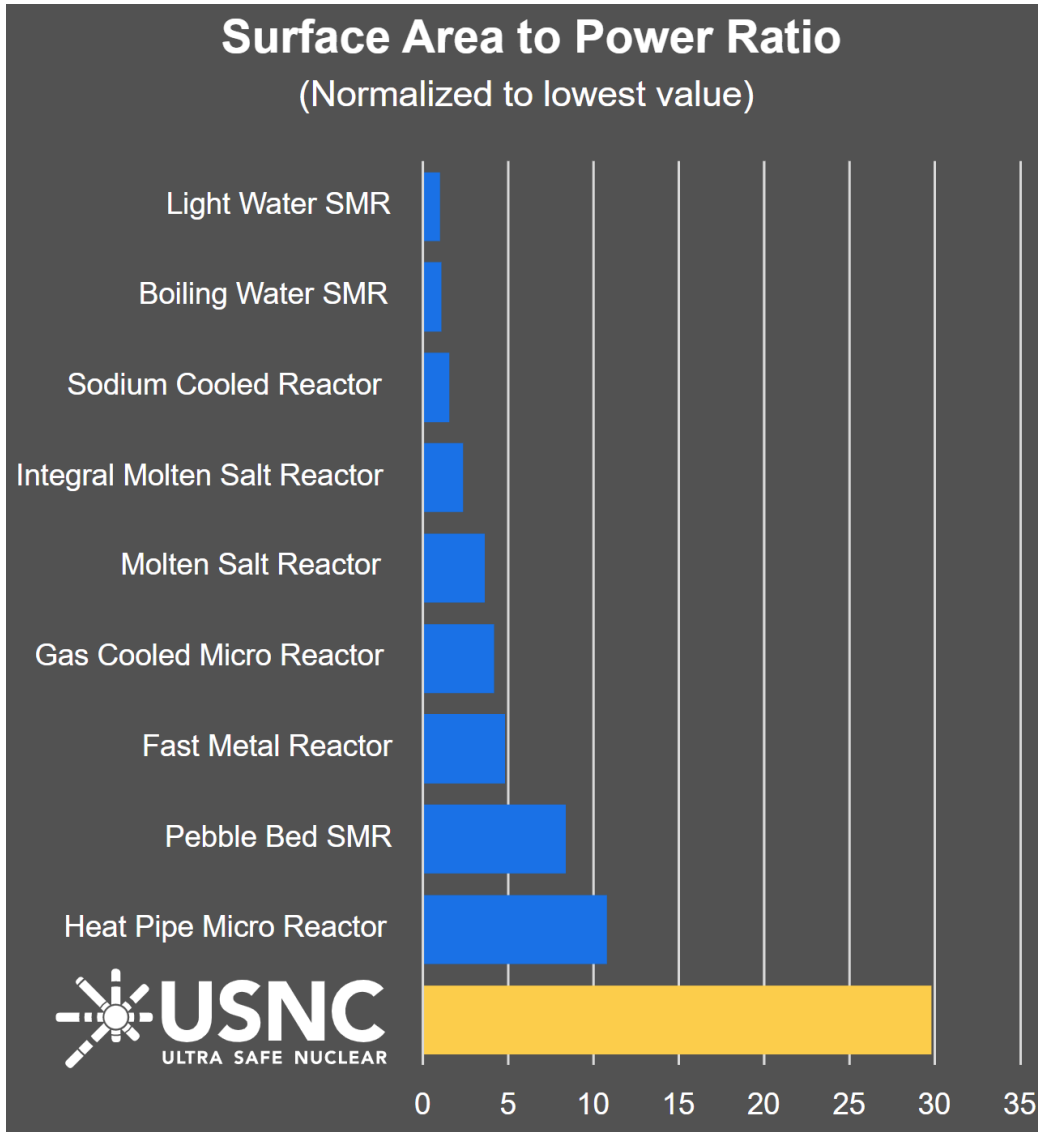

# Reactor Design: USNC Micro-Modular Reactor (MMR)



## Fluid Characteristics:

- Helium
  - 3 MPa,
  - 300°C - 630°C
- Molten Salt
  - 0.5 MPa,
  - 270°C - 565°C

## Safety Methodology:

- Retain all fission products
- Strong negative feedback with temperature
- Cooling through natural forces (passive)

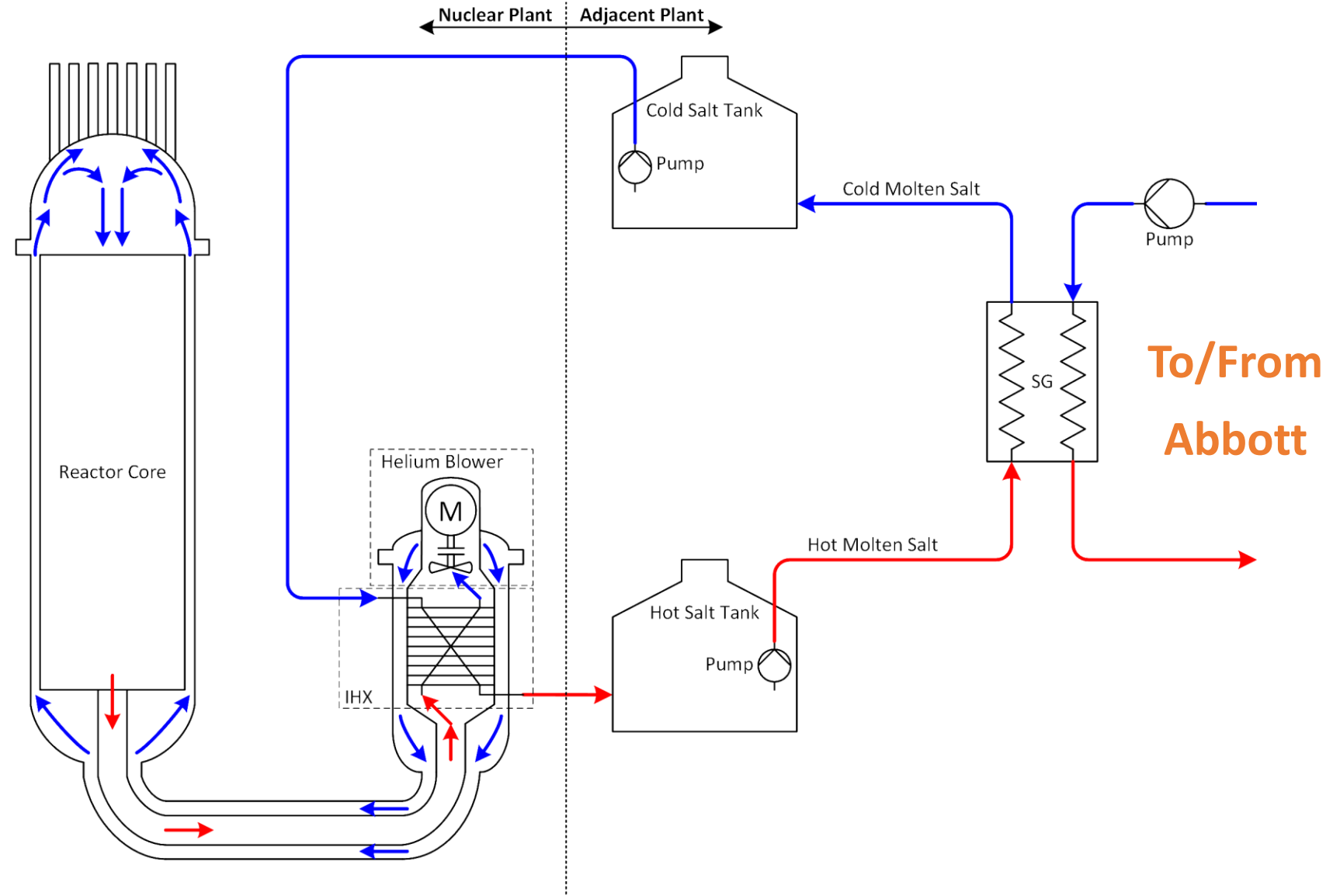

# MMR Fuel: TRISO (TRi-structural ISOtropic)



Credit: [USNC](#)

- Builds on testing and qualification of TRISO fuel by DOE's AGR program
  - TRISO fuel particles
  - TRISO in Fully Ceramic Micro-encapsulated (FCM<sup>®</sup>) fuel pellet for improved fission product retention
- Pilot Fuel Manufacturing (PFM) facility
  - Complete TRISO and FCM manufacturing capability
  - NRC agreement state license
  - Demonstrates manufacturing and QC processes and equipment
  - Manufacturing of enriched MMR fuel for qualification (2023)
- Fuel Qualification
  - Irradiation testing in the High Flux Reactor (2024)
  - Regulatory approval (2027)



Illustration of FCM fuel pellet interior



Manufactured FCM fuel pellet

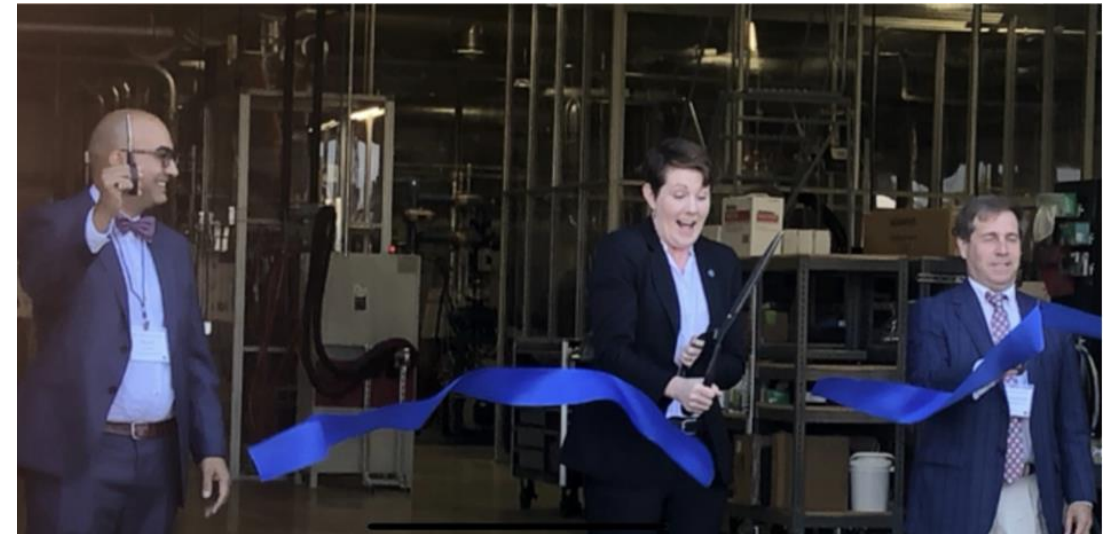

PFM dedication, August 2022



# MMR Fuel: Factory and Manufacturing Strategy



- **Staged Approach:** scaling our manufacturing operations to successively implement learnings and reduce uncertainty in implementing manufacturing at greater scale
  - Our Pilot Fuel Manufacturing Facility (PFM) is outfitted with the same type and scale of process equipment that will populate full-scale manufacturing operations at our upcoming Fuel Factory
  - Successful operation and production of single modules strengthens our fuel fabrication licensing basis and reduces execution risk of full-scale manufacturing
- **Partnership:** USNC is forming a joint venture partnership with Framatome to manufacture our MMR fuel at their licensed fuel facility in Richland, WA. A partner:
  - Accelerates our timeline to first product by utilizing a fuel manufacturing site under active NRC license
  - De-risks our execution timeline by bringing invaluable expertise in the economical and safe manufacturing nuclear fuel assemblies at commercial scale
  - Exploits existing deconversion capabilities and avoids the need for a new transportation solution
  - Provides the ideal business incentive arrangement (e.g., the sharing of costs, risks, and opportunities)
- **Proactive Approach:** we are prioritizing critical path items and applying significant buffer to limit schedule slippage, especially:
  - Critical path licensing activities (e.g., Integrated Safety Analysis underway)
  - Long lead time capital expenses
  - Key procurements (e.g., EUP in collaboration with Urenco)



# Licensing Documentation



Document Title	Type	Actual/Estimated Submittal Date	Current Status
Applicability of 104(c) Licensing Path	WP	Submitted: Jun 2022	Discussions
Proposed Contents of PSAR in Accordance with NUREG-1537	WP	Submitted: Aug 2022	Discussions
Quality Assurance Program Description	TR	Submitted: Oct 2022	Approved, SE issued 5-6-2023
Applicability of Nuclear Regulatory Commission Regulations	TR	Submitted: Dec 2022	Under review   Public Meeting 6-8-2023
Fuel Qualification Methodology	TR	Submitted: Feb 2023	Under review
Safeguards Information Protection Plan	Plan	Submitted: Feb 2023	Under review   Closed Meeting 6-27-2023
Scenario Identification and SSC Safety Classification Methodology	TR	Q3 CY2023	
MMR Instrumentation & Control System Architecture	TR	Q3 CY2023	
MMR Principal Design Criteria	TR	Q3 CY2023	
Safety Analysis (Nuclear/Thermal-hydraulic/Structural) Analysis Methodology	TR	Q3 CY2023	
Safety Analysis (Nuclear/Thermal-hydraulic/Structural) Code V&V	TR	Q4 CY2023	
Environmental Analysis	Report	Q1 CY2024	Geological and Meteorological Review Topics   Public Meeting 2-7-2023
Preliminary Safety Analysis Report	Report	Q2 CY2024	

WP = White Paper | TR = Topical Report





Thanks for you attention,  
Questions?



UNIVERSITY OF  
**ILLINOIS**  
URBANA-CHAMPAIGN



# Section 31 of the Atomic Energy Act of 1954, as Amended



SEC. 31. RESEARCH ASSISTANCE.— a. The Commission is directed to exercise its powers in such manner as to insure the continued conduct of research and development and training activities in the fields specified below, by private or public institutions or persons, and to assist in the acquisition of an ever-expanding fund of theoretical and practical knowledge in such fields. To this end the Commission is authorized and directed to make arrangements (including contracts, agreements, and loans) for the conduct of research and development activities relating to—

- (1) nuclear processes;
- (2) the theory and production of atomic energy, including processes, materials, and devices related to such production;
- (3) utilization of special nuclear material and radioactive material for medical, biological, agricultural, health, or military purposes;
- (4) utilization of special nuclear material, atomic energy, and radioactive material and processes entailed in the utilization or production of atomic energy or such material for all other purposes, including industrial or commercial uses, the generation of usable energy, and the demonstration of advances in the commercial or industrial application of atomic energy; and
- (5) the protection of health and the promotion of safety during research and production activities.